



For Members of  
**RADIO MANUFACTURERS SERVICE**  
 A PHILCO SERVICE PLAN

**SERVICE BULLETIN**  
 No. 243

## Model 37-602

### Specifications

- TYPE CIRCUIT:** Superheterodyne with pentode output.
- POWER SUPPLY:** 115 V., 25 or 60 cycle, A. C.; D. C.
- TUBES USED:** 1 type 6A8G, Osc. Det., 1 type 6K7G I.F. Amplifier, 1 type 6Q7G, 2nd Det. 1st audio, 1 type 25A6G output, 1 type 25Z6G rectifier.
- FREQUENCY RANGE:** 530--1800 K.C.
- INTERMEDIATE FREQUENCY:** 470 K.C.
- CURRENT CONSUMPTION:** 55 watts.
- SPEAKER:** B-4.
- POWER OUTPUT:** 3/4 watt.

### Adjusting Compensating Condensers

To accurately adjust the compensating condensers in the Model 37-602 receiver, it is necessary to use a signal generator of high stability on all frequencies such as the **PHILCO Model 088 Signal Generator**. This instrument has a continuous frequency range from 110 to 20,000 K.C., and is designed to meet every requirement of the serviceman.

An output meter is also needed,—**PHILCO Model 025 Circuit Tester** includes a very sensitive output meter.

Convenient tools to use in adjusting the condensers are the **PHILCO No. 3164 Fibre Wrench** and **No. 27-7059 Fibre Handled Screw-driver**.

The locations of the various compensating condensers are shown in Fig. 1. Connect the output meter to the plate and cathode contacts of the (25A6G) power tube and adjust it to use the 0-30 volt range.

### Intermediate Frequency Circuit

1. Turn the gang condenser to the maximum capacity position (extreme clockwise) and set the Volume Control of the receiver at the maximum position (extreme clockwise).
2. Connect the signal generator output lead through a .1 mfd. condenser to the grid of the 6K7G tube, and the generator ground lead to any point of chassis.
3. Set the signal generator at 470 K.C. and adjust ⑲ and ⑳ for maximum reading on the output meter.
4. Remove signal generator output lead and .1 mfd. condenser, from the grid of 6K7G and connect it to the grid of 6A8G. Now adjust compensators ㉑ and ㉒ for maximum reading on the output meter.

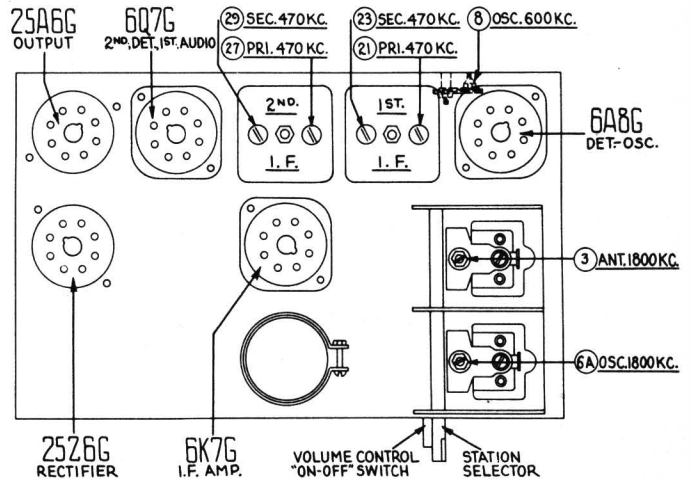

Fig. 1. Location of Compensators

### Radio Frequency Circuit

1. Remove the signal generator output lead from the 6A8G tube and connect it to the aerial lead of the receiver through a 100 mmfd. condenser. Turn the gang condenser to the minimum capacity position (extreme counter clockwise) and place a .006" (six thousandth inch) gauge between the stator and rotor plates. Now turn the gang clockwise until stator and rotor plates touch gauge.
2. Remove gauge from gang condenser. Now set signal generator at 900 K.C. (using second harmonic (1800 K.C.)) adjust compensators ④A and ④ for maximum reading on the output meter.
3. Turn the signal generator and receiver gang condenser to 600 K.C., and adjust compensator ④. In doing so, the gang condenser must be rolled slightly above and below the 600 K.C. signal until the maximum reading is indicated on the output meter.
4. Turn the gang condenser to 1800 K.C. and signal generator to 900 K.C., (using second harmonic of signal generator 1800 K.C.), readjust compensator ④A for maximum reading on output meter. Set gang as given in paragraph 1, for this adjustment.
5. Turn the gang condenser and signal generator to 1400 K.C., readjust compensator ④ for maximum reading on output meter. After the above adjustments are completed and receiver is placed in the cabinet, the dial pointer is properly placed by turning the signal generator to 1000 K.C. Then tune receiver for maximum signal. The dial pointer is then placed on gang shaft, so that it indicates 1000 K.C. on dial.

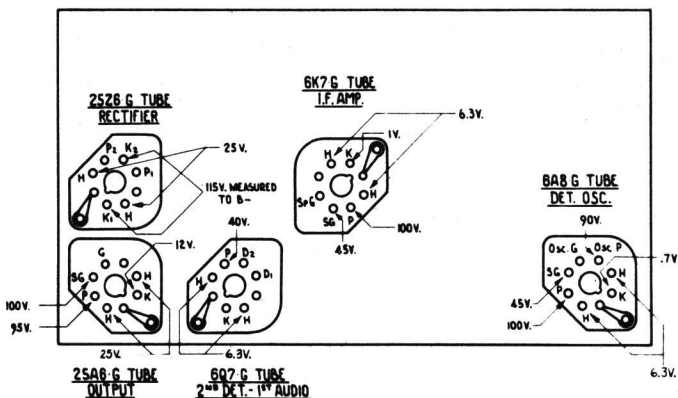

Fig. 2. Tube Sockets as viewed from underside of chassis. (Voltages measured from socket contacts to B—)

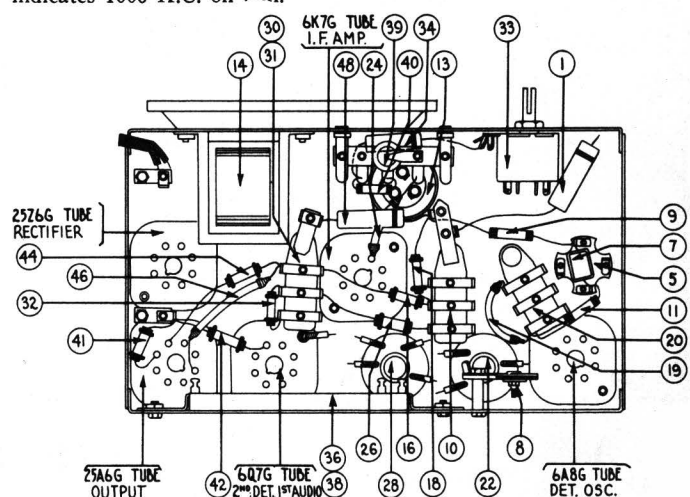

Fig. 3. Base View

Replacement Parts for Model 37-602

Table with 3 columns: Schematic Number, Part and Description, Part No., Price List. Lists parts 1 through 20.

Table with 3 columns: Schematic Number, Part and Description, Part No., Price List. Lists parts 21 through 35.

Table with 3 columns: Schematic Number, Part and Description, Part No., Price List. Lists parts 36 through 50.

PRICES SUBJECT TO CHANGE WITHOUT NOTICE

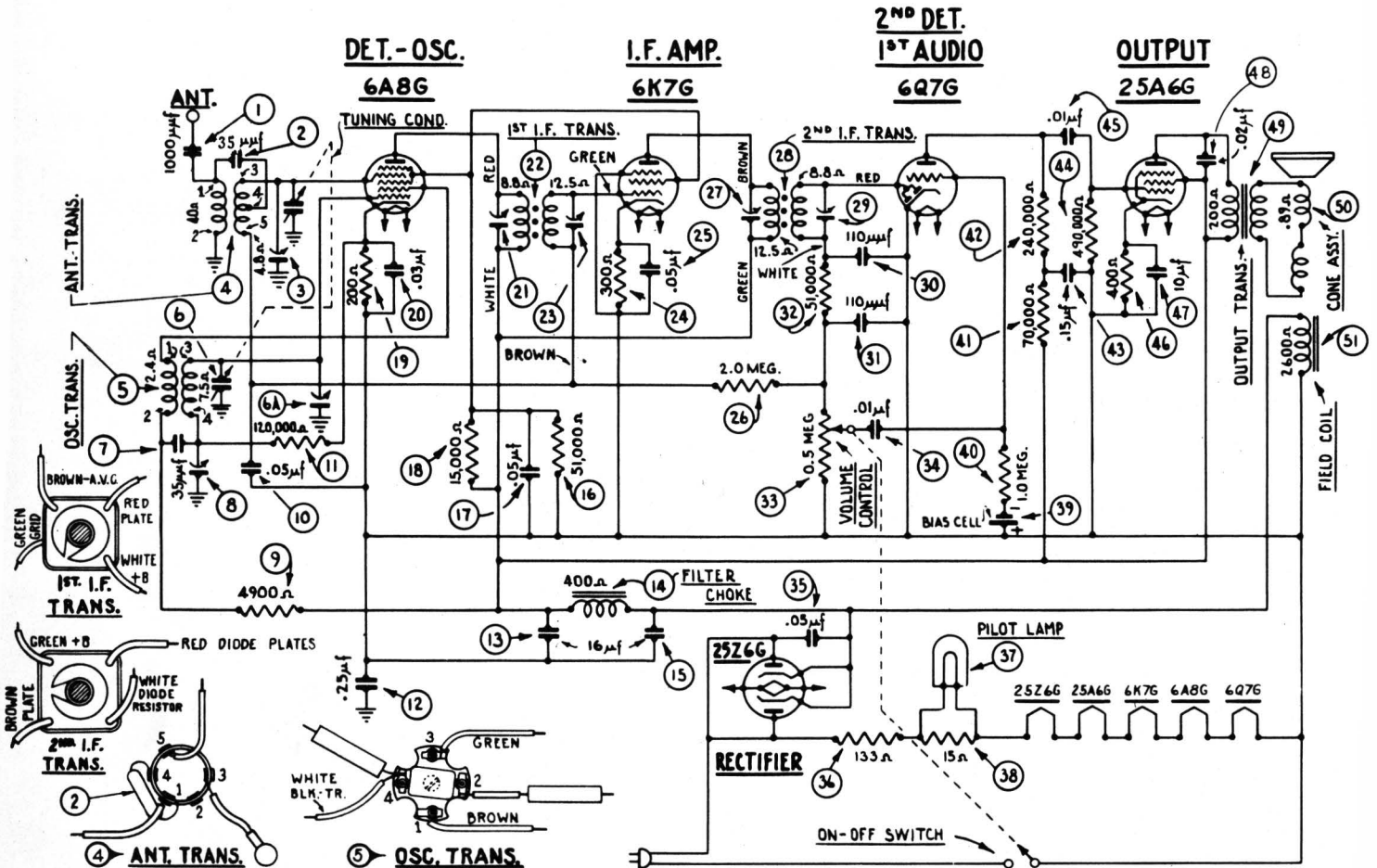

Fig. 4. Schematic Wiring Diagram